

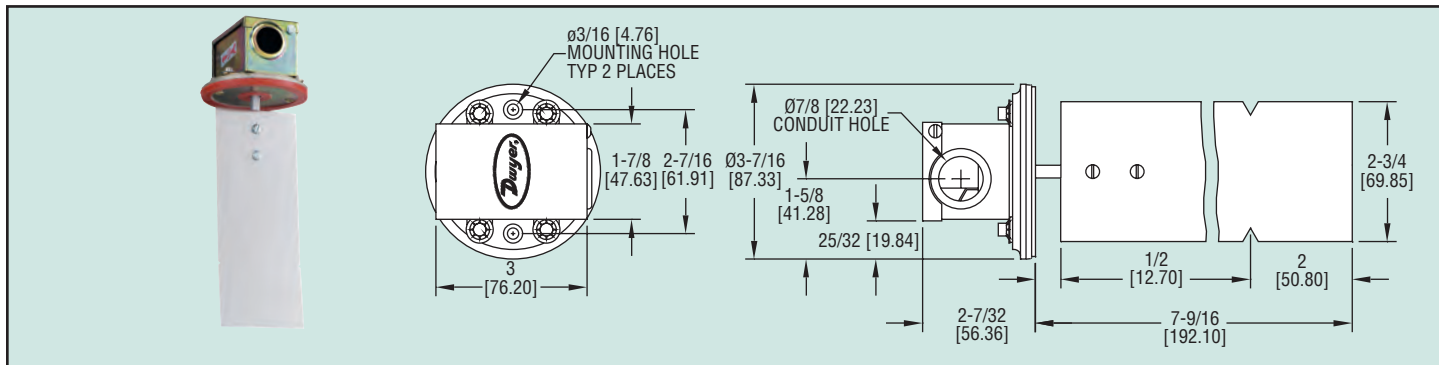

Model
530

Air Flow Switch

Adjustable from 400-1600 FPM, Stainless Steel Vane



The Model 530 air flow switch provides excellent sensitivity and reliability at a very reasonable price. Quality features include a rugged die cast body, stainless steel vane and SPDT snap switch. Unit is field adjustable from 400-1600 FPM. Mounting is fast and simple, with only two screws needed. Vane fits 6 in. or larger ducts.

Model 530, Air Flow Switch

Range 400-1600 FPM mounted on top of horizontal duct.

CAUTION: For use only with air or non-combustible non-corrosive gases. Unit is not sealed against dust.

SPECIFICATIONS

Service: Air and non-combustible gas flow.

Wetted Materials: Contact factory.

Vane: Stainless steel.

Temperature Limit: 180°F (82°C).

Switch Type: SPDT.

Electrical Rating: 125 VAC - 9.8 amp full load 58.8 amp locked rotor; 250 VAC - 4.9 amp full load 29.4 amp locked rotor; Pilot rating: 470 VA at 125, 250 VAC; Resistive: 15 amp at 125, 250, or 480 VAC.

Electrical Connections: Screw type terminal.

Conduit Connection: 7/8" conduit hole.

Mounting Orientation: Horizontal duct flow.

Set Point Adjustment: Screw type.

Weight: 1 lb 1 oz (481.94 g)

Agency Approvals: CE, CSA, UL.